



PRODUCT SPECIFICATION



MX150 16 WAY HYBRID CONNECTOR SYSTEM

REVISION: F2	ECR/ECN INFORMATION: EC No: UAU2016-1352 DATE: 3/09/2016	TITLE: MX150 16 WAY HYBRID CONNECTOR SYSTEM	SHEET No. 1 of 12
DOCUMENT NUMBER: PS-33476-000	CREATED / REVISED BY: A. PROFFITT	CHECKED BY: A. DING	APPROVED BY: V. KOSHY



PRODUCT SPECIFICATION

Table of Contents

1.0	Scope	3
2.0	Product Description.....	3
2.1.	Direct Connect (wire to board application).....	3
2.2.	Inline Applications (wire to wire application)	3
2.3.	Receptacle Assembly.....	4
2.4.	Blade Assembly	4
2.5.	Product Name and Series Numbers.....	5
3.0	Integral Components and Accessories.....	5
3.1.	Integral Components.....	5
3.1.1.	Receptacle Terminals.....	5
3.1.2.	Blade Terminals	6
3.1.3.	Applicable Wires	7
3.2.	Accessories	7
3.2.1.	Wire Harness Retention Clip – Recommended	7
3.2.2.	Backshell – Not Available	7
3.2.3.	Cavity Plugs	7
4.0	Applicable Documents and Specifications.....	8
5.0	Ratings	8
5.1.	Voltage – Operating	8
5.2.	Voltage – Isolation Resistance	8
5.3.	Current Rating.....	8
5.4.	Temperature	8
5.5.	Flammability.....	8
6.0	Performance	9
6.1.	Electrical	9
6.2.	Mechanical.....	10
6.3.	Environmental.....	11
6.4.	This Product Conforms to Din 40 050 1993 with the Following Conditions.	12
7.0	Packaging.....	12
8.0	Gages and Fixtures.....	12
9.0	Other Information.....	12

REVISION: F2	ECR/ECN INFORMATION: EC No: UAU2016-1352 DATE: 3/09/2016	TITLE: MX150 16 WAY HYBRID CONNECTOR SYSTEM	SHEET No. 2 of 12
DOCUMENT NUMBER: PS-33476-000	CREATED / REVISED BY: A. PROFFITT	CHECKED BY: A. DING	APPROVED BY: V. KOSHY



PRODUCT SPECIFICATION

1.0 SCOPE

This product specification covers the 3.50 mm (0.138 inch) centerline (pitch) 16 way hybrid MX150 sealed product line with an in-line connection system terminated with wires using crimp technology.

2.0 PRODUCT DESCRIPTION

2.1. DIRECT CONNECT (WIRE TO BOARD APPLICATION)

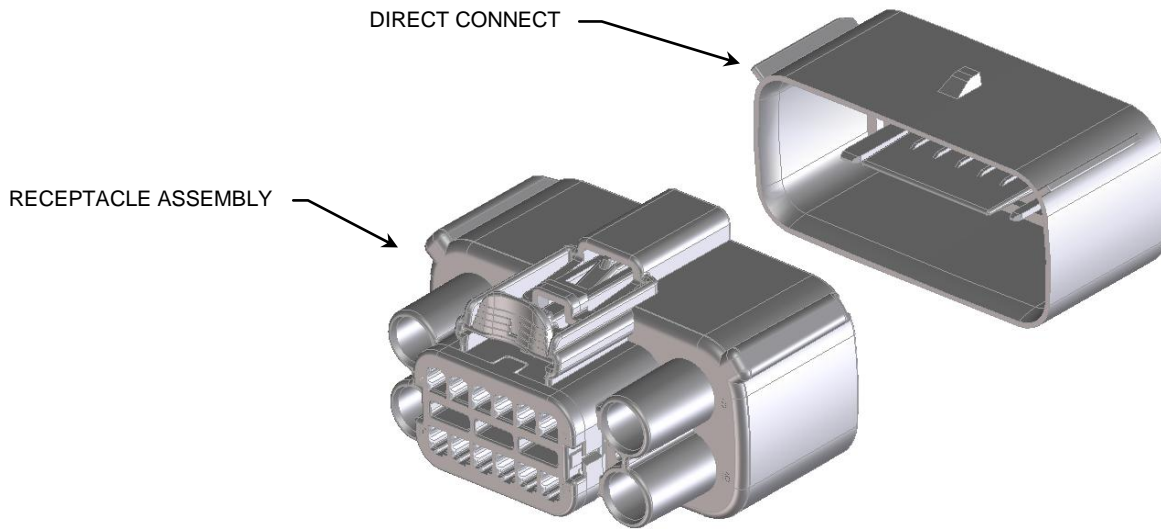

2.2. INLINE APPLICATIONS (WIRE TO WIRE APPLICATION)

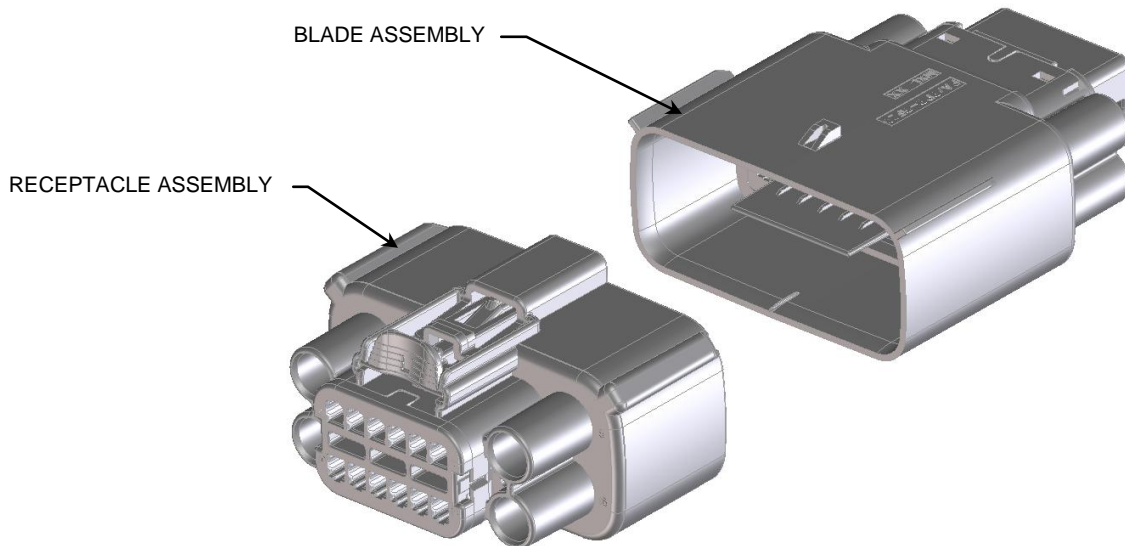

REVISION: F2	ECR/ECN INFORMATION: EC No: UAU2016-1352 DATE: 3/09/2016	TITLE: MX150 16 WAY HYBRID CONNECTOR SYSTEM	SHEET No. 3 of 12
DOCUMENT NUMBER: PS-33476-000	CREATED / REVISED BY: A. PROFFITT	CHECKED BY: A. DING	APPROVED BY: V. KOSHY



PRODUCT SPECIFICATION

2.3. RECEPTACLE ASSEMBLY

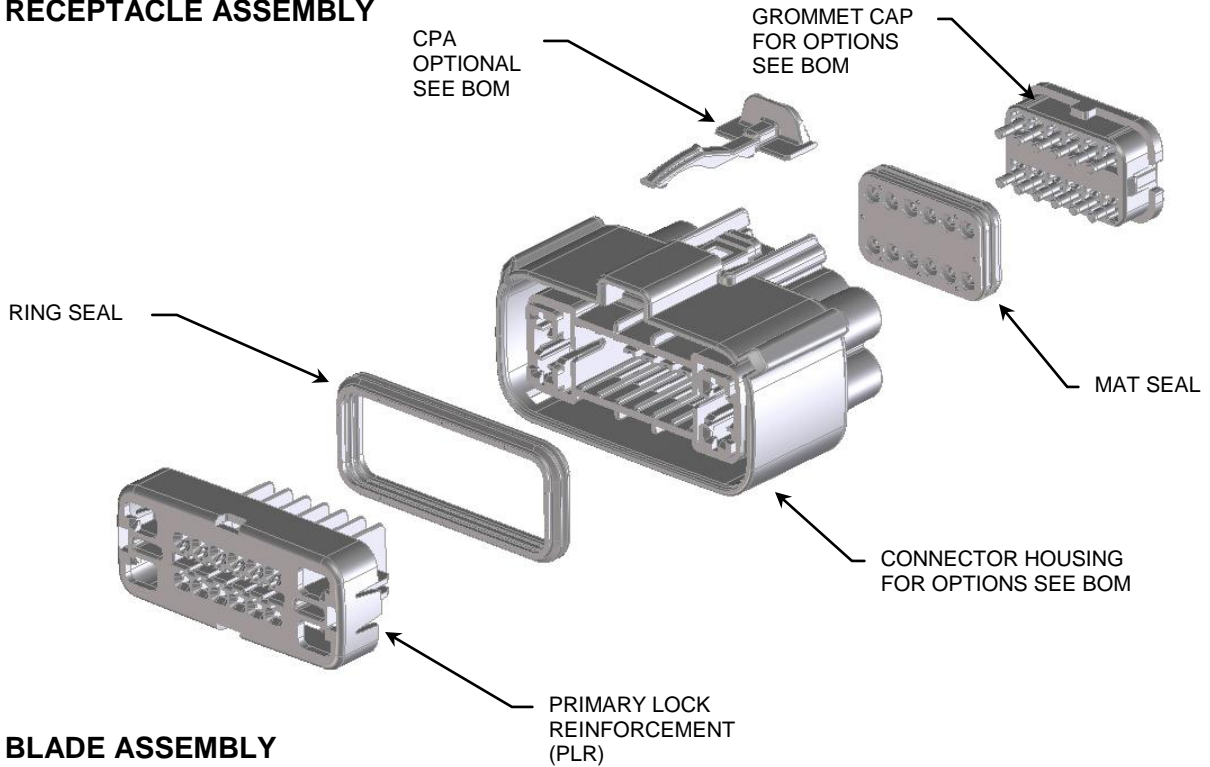

2.4. BLADE ASSEMBLY

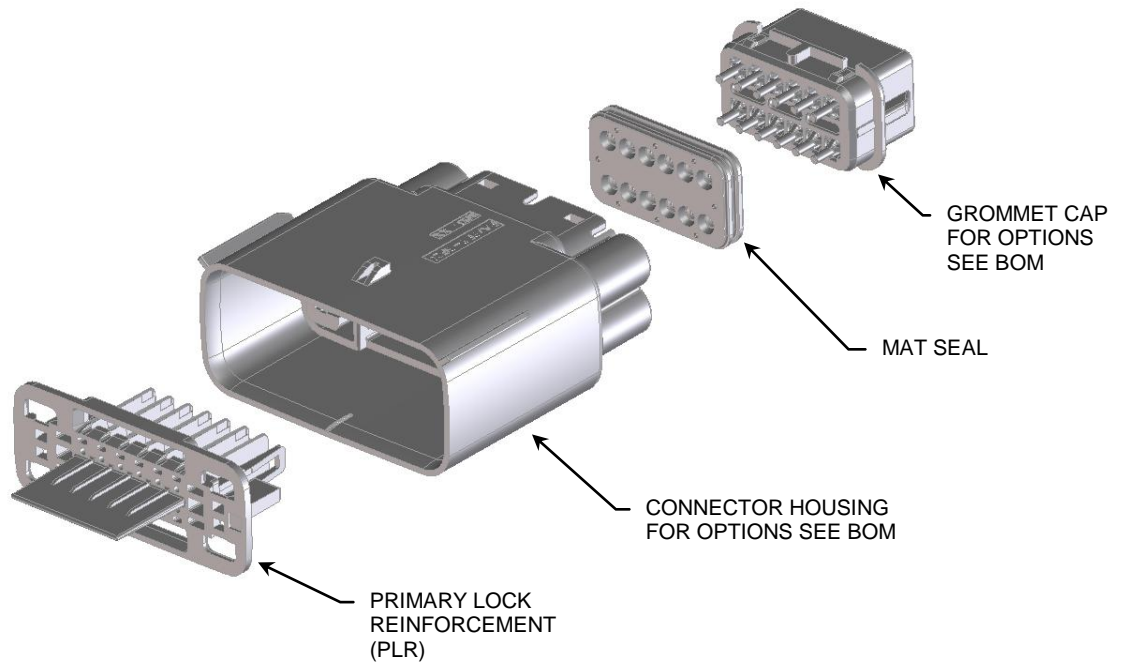

REVISION: F2	ECR/ECN INFORMATION: EC No: UAU2016-1352 DATE: 3/09/2016	TITLE: MX150 16 WAY HYBRID CONNECTOR SYSTEM	SHEET No. 4 of 12
DOCUMENT NUMBER: PS-33476-000	CREATED / REVISED BY: A. PROFFITT	CHECKED BY: A. DING	APPROVED BY: V. KOSHY



PRODUCT SPECIFICATION

2.5. PRODUCT NAME AND SERIES NUMBERS

Refer to listed document number for part availability, dimensions, material, marking information, packaging information, interface definition, and configuration options etc.

Product Name	Document Number	Series
16 Way Hybrid Female Assembly	SD-33476-161/181*	33476*
16 Way Hybrid Female Assembly	SD-34985-8001 – Assembly Drawing SD-34985-8002 – Bill of Materials	34985
16 Way Hybrid Male Assembly	SD-34986-8001 – Assembly Drawing SD-34986-8002 – Bill of Materials	34986

*Obsolete – new series is 34985

3.0 INTEGRAL COMPONENTS AND ACCESSORIES

Integral components and accessories are sold separately.

3.1. INTEGRAL COMPONENTS

3.1.1. Receptacle Terminals

For crimping information see the Receptacle Terminal Application Specification listed in section [4.0](#).

Terminal Attributes	Document Number
MX150 Receptacle, Mat Seal, High Performance, Sn, M3 Grip Code	SD-33012-002
MX150 Receptacle, Mat Seal, High Performance, Sn, 22 Grip Code	
MX150 Receptacle, Mat Seal, High Performance, Sn, 18 Grip Code	
MX150 Receptacle, Mat Seal, High Performance, Sn, 14 Grip Code	
MX150 Receptacle, Mat Seal, High Performance, Au*, M3 Grip Code	
MX150 Receptacle, Mat Seal, High Performance, Au*, 22 Grip Code	
MX150 Receptacle, Mat Seal, High Performance, Au*, 18 Grip Code	
MX150 Receptacle, Mat Seal, High Performance, Au*, 14 Grip Code	
TYCO 2.8mm Receptacle, Cable Seal, Sn, 22awg	TE Connectivity Drawing C-1326032
TYCO 2.8mm Receptacle, Cable Seal, Sn, 20awg	
TYCO 2.8mm Receptacle, Cable Seal, Sn, 18awg	
TYCO 2.8mm Receptacle, Cable Seal, Sn, 16awg	
TYCO 2.8mm Receptacle, Cable Seal, Sn, 14awg	
TYCO 2.8mm Receptacle, Cable Seal, Sn, 12awg	

*Shorting bar applications

REVISION: F2	ECR/ECN INFORMATION: EC No: UAU2016-1352 DATE: 3/09/2016	TITLE: MX150 16 WAY HYBRID CONNECTOR SYSTEM	SHEET No. 5 of 12
DOCUMENT NUMBER: PS-33476-000	CREATED / REVISED BY: A. PROFFITT	CHECKED BY: A. DING	APPROVED BY: V. KOSHY



PRODUCT SPECIFICATION

3.1.2. Blade Terminals

For crimping information see the Blade Terminal Application Specification listed in section [4.0](#).

Terminal Attributes	Document Number
MX150 Blade, Mat Seal, High Performance, Sn, M3 Grip Code	SD-33000-001
MX150 Blade, Mat Seal, High Performance, Sn, 22 Grip Code	
MX150 Blade, Mat Seal, High Performance, Sn, 18 Grip Code	
MX150 Blade, Mat Seal, High Performance, Sn, 14 Grip Code	
MX150 Shorting Bar Blade, Mat Seal, High Performance, Au*, 18 Grip Code	SD-31296-001
TYCO 2.8mm Blade, Cable Seal, Sn, 22awg	TE Connectivity Drawing C-1326031
TYCO 2.8mm Blade, Cable Seal, Sn, 20awg	
TYCO 2.8mm Blade, Cable Seal, Sn, 18awg	
TYCO 2.8mm Blade, Cable Seal, Sn, 16awg	
TYCO 2.8mm Blade, Cable Seal, Sn, 14awg	
TYCO 2.8mm Blade, Cable Seal, Sn, 12awg	

*Shorting bar applications

REVISION: F2	ECR/ECN INFORMATION: EC No: UAU2016-1352 DATE: 3/09/2016	TITLE: MX150 16 WAY HYBRID CONNECTOR SYSTEM	SHEET No. 6 of 12
DOCUMENT NUMBER: PS-33476-000	CREATED / REVISED BY: A. PROFFITT	CHECKED BY: A. DING	APPROVED BY: V. KOSHY



PRODUCT SPECIFICATION

3.1.3. Applicable Wires

3.1.3.1. Wire Size

See Section [6.0](#) for temperature range and recommended wire type within this system.

3.1.3.2. ISO Wire

Per the listed wire specifications where the insulation diameter is within 1.20mm to 3.00mm

- GMW15626 February 2008
 - o FLR2X-A
- ES-AU5T-1A348-AA Rev D
 - o 3TAD

3.1.3.3. SAE Wire

Per the listed wire specifications where the insulation diameter is within 1.50mm to 3.30mm.

- ESB-ML123-A 2003
- SAE J1128 DEC 2005
 - o TXL

3.1.3.4. Terminal Service Tool

See the Connector Application Specification listed in section [4.0](#).

3.2. ACCESSORIES

3.2.1. Wire Harness Retention Clip – Recommended

For further information contact your sales engineer.

3.2.2. Backshell – Not Available

3.2.3. Cavity Plugs

*Seal plugs are not to be used to replace shorting bar terminals.

Information	Description	Document Number
MX150 Cavity Plug, Natural	34345-0001	SD-34345-001

REVISION: F2	ECR/ECN INFORMATION: EC No: UAU2016-1352 DATE: 3/09/2016	TITLE: MX150 16 WAY HYBRID CONNECTOR SYSTEM	SHEET No. 7 of 12
DOCUMENT NUMBER: PS-33476-000	CREATED / REVISED BY: A. PROFFITT	CHECKED BY: A. DING	APPROVED BY: V. KOSHY



PRODUCT SPECIFICATION

4.0 APPLICABLE DOCUMENTS AND SPECIFICATIONS

Document Title	Document Number
UL File Number	Not Applicable
CSA File Number	Not Applicable
TUV License number	Not Applicable
IMDS Report	Available upon request
Environmental Compliance	Available on molex.com
Connector Application Specification	AS-33472-100
Cavity Plug Information	SD-34345-001
MX150 Terminal Product Specification	PS-33012-002
MX150 Receptacle Terminal Application Specification	AS-33012-002
MX150 Blade Terminal Application Specification	AS-33000-001
TYCO 2.8mm Receptacle Terminal Application Specification	TE Connectivity Document 114-13013
TYCO 2.8mm Blade Terminal Application Specification	
Connector Test Summary	TBD
PLR Transit Related Product Specification	PS-34646-001
MX150 CPA Installation Guide	AS-33611-001

5.0 RATINGS

5.1. VOLTAGE – OPERATING

Operating Voltage: 14 Volts DC Maximum

5.2. VOLTAGE – ISOLATION RESISTANCE

100MΩ Minimum when 500 Volts DC between adjacent terminals and terminals to ground

5.3. CURRENT RATING

See the Terminal Product Specification listed in section [4.0](#).

5.4. TEMPERATURE

Non-operating: - 40 C° to + 125 C°

Operating: - 40 C° to + 125 C°

5.5. FLAMMABILITY

The burn rate of the plastic material when tested to ISO 3795 shall not exceed 100 mm/min.

REVISION: F2	ECR/ECN INFORMATION: EC No: UAU2016-1352 DATE: 3/09/2016	TITLE: MX150 16 WAY HYBRID CONNECTOR SYSTEM	SHEET No. 8 of 12
DOCUMENT NUMBER: PS-33476-000	CREATED / REVISED BY: A. PROFFITT	CHECKED BY: A. DING	APPROVED BY: V. KOSHY



PRODUCT SPECIFICATION

6.0 PERFORMANCE

Operating Conditions	Terminal Size	Wire Range	Series	Recommended Wire Type*	Recommended Terminal Plating Type
Temperature Class III Vibration Class I	1.5mm	1.20 – 2.69 mm	34985/34986	FLR2X	Sn*
		1.40 – 2.69 mm	ALL		
	2.8mm	1.50 – 3.30 mm			

*Must be compliant to the wire specification listed in section [3.1.3](#)

**Au for shorting bar applications

6.1. ELECTRICAL

ITEM	DESCRIPTION	TEST CONDITION	REQUIREMENT
1	Contact Resistance (Low Level)	Mate connectors: limiting the open circuit voltage of 20 mV and a maximum current of 100 mA .	10 milliohms MAXIMUM
2	Contact Resistance @ Rated Current (Voltage Drop)	Mate connectors: apply a 5 ampere/ 1.0 mm² current	10 milliohms MAXIMUM
3	Isolation Resistance	Apply a voltage of 500 VDC between adjacent terminals and between terminals to ground.	20 Meg ohms MINIMUM
4	Temperature Rise (via Current Cycling)	Mate terminals: measure the temperature rise at the rated current after: 1008 hours of bench top testing (45 minutes ON and 15 minutes OFF per hour).	Temperature rise over Ambient: +55 C° MAXIMUM

REVISION: F2	ECR/ECN INFORMATION: EC No: UAU2016-1352 DATE: 3/09/2016	TITLE: MX150 16 WAY HYBRID CONNECTOR SYSTEM	SHEET No. 9 of 12
DOCUMENT NUMBER: PS-33476-000	CREATED / REVISED BY: A. PROFFITT	CHECKED BY: A. DING	APPROVED BY: V. KOSHY



PRODUCT SPECIFICATION

6.2. MECHANICAL

ITEM	DESCRIPTION	TEST CONDITION	REQUIREMENT
5	Connector Mate/ Unmate Forces	Mate and unmate connector (male to female) at a rate of 50 ± 6 mm ($2 \pm \frac{1}{4}$ inch) per minute.	75 Newtons MAXIMUM
			Unmate 110 Newtons MINIMUM
6	Terminal Retention Force (in Housing)	Axial pullout force on the terminal in the housing at a rate of 50 ± 6 mm ($2 \pm \frac{1}{4}$ inch) per minute.	90 Newtons MINIMUM
7	Terminal Insertion Force (into Housing)	Apply an axial insertion force on the terminal at a rate of 50 ± 6 mm ($2 \pm \frac{1}{4}$ inch) per minute.	30 Newtons MAXIMUM
8	Connector Audible Feedback	The connector lock must provide audible feedback during connector mating at a rate of 50 ± 6 mm ($2 \pm \frac{1}{4}$ inch) per minute.	7dB over Ambient (C scale)
9	Polarization Feature Effectiveness	Connector must be polarized to prevent mating with similar connectors or incorrect orientation	145 Newtons MINIMUM
10	Terminal Position Assurance (TPA) Insertion Force (into housing)	The force to insert the TPA from the preload (as shipped) position to the final position at a rate of 50 ± 6 mm ($2 \pm \frac{1}{4}$ inch) per minute.	60 Newtons MAXIMUM
11	Terminal Position Assurance (TPA) Extraction Force (in housing)	The force to extract the TPA from the final position to the preload position (as shipped) at a rate of 50 ± 6 mm ($2 \pm \frac{1}{4}$ inch) per minute.	60 Newtons MAXIMUM
12	Connector Position Assurance (CPA) Insertion Force (into housing)	The force to insert the CPA from the preload (as shipped) position to the final position at a rate of 50 ± 6 mm ($2 \pm \frac{1}{4}$ inch) per minute.	40 Newtons MINIMUM (unmated)
			15 Newtons MAXIMUM (fully mated)
13	Connector Position Assurance (CPA) Extraction Force (in housing)	The force to insert the CPA from the preload (as shipped) position to the final position at a rate of 50 ± 6 mm ($2 \pm \frac{1}{4}$ inch) per minute.	60 Newtons MAXIMUM
14	Locator Clip Insertion Force (in housing)	The force to insert the locator clip to the final (as shipped) position at a rate of 50 ± 6 mm ($2 \pm \frac{1}{4}$ inch) per minute.	30 Newtons MAXIMUM

REVISION: F2	ECR/ECN INFORMATION: EC No: UAU2016-1352 DATE: 3/09/2016	TITLE: MX150 16 WAY HYBRID CONNECTOR SYSTEM	SHEET No. 10 of 12
DOCUMENT NUMBER: PS-33476-000	CREATED / REVISED BY: A. PROFFITT	CHECKED BY: A. DING	APPROVED BY: V. KOSHY



PRODUCT SPECIFICATION

15	Locator Clip Extraction Force (in housing)	The force to extract the locator clip from the final (as shipped) position to out at a rate of 50 ± 6 mm (2 ± ¼ inch) per minute.	110 Newtons MINIMUM
-----------	---	--	----------------------------

6.3. ENVIRONMENTAL

ITEM	DESCRIPTION	TEST CONDITION	REQUIREMENT						
16	Field Correlated Life Test (FCLT)	Mate connectors up to 1 cycle and expose to environment per SAE/USCAR-20.	20 milliohms MAXIMUM						
17	Durability	Mate connectors up to 10 cycles prior to environmental tests.	10 milliohms MAXIMUM & Discontinuity < 1 microsecond						
18	Thermal Shock (Electrical)	Mate connectors per durability; expose to 100 cycles of: <table style="margin-left: 20px; border: none;"> <tr> <td style="text-align: center;"><u>Temperature C°</u></td> <td style="text-align: center;"><u>Duration (Minutes)</u></td> </tr> <tr> <td style="text-align: center;">-40 +0/-3</td> <td style="text-align: center;">30</td> </tr> <tr> <td style="text-align: center;">+125 +3/-0</td> <td style="text-align: center;">30</td> </tr> </table>	<u>Temperature C°</u>	<u>Duration (Minutes)</u>	-40 +0/-3	30	+125 +3/-0	30	10 milliohms MAXIMUM & Discontinuity < 1 microsecond
<u>Temperature C°</u>	<u>Duration (Minutes)</u>								
-40 +0/-3	30								
+125 +3/-0	30								
19	High Temperature Exposure (Sealing)	Mate connectors per durability and expose to 1008 hours at 125 ± 2°C	28 kPa for 15 seconds MINIMUM pressure/vacuum & Submersion for 30 minutes & Isolation Resistance of 20 Meg ohms @ 500 VDC MINIMUM						
20	Temperature/ Humidity (Sealing)	Mate connectors per durability and expose connector system to forty 8 -hour cycles of combined heating and humidity exposure -40 °C and 125 °C at 0% to 90% RH	28 kPa for 15 seconds MINIMUM pressure/vacuum & Submersion for 30 minutes & Isolation Resistance of 20 Meg ohms @ 500 VDC MINIMUM						
21	Fluid Resistance (Sealing)	Submerge connector assemblies in the following fluids: gasoline, *diesel fuel, engine oil, ethanol, power steering fluid, automatic transmission fluid, engine coolant, and brake fluid.	Submersion for 30 minutes & Isolation Resistance of 20 Meg ohms @ 500 VDC MINIMUM						
22	Vibration/ Mechanical Shock (Electrical)	Mate connectors per durability. Connector assembly shall be vibrated for (8 hours / axes @ 12.1 Grms, 10 shocks @ 35 Gs / axes) Coupled to engine.	10 milliohms MAXIMUM & Discontinuity < 1 microsecond						

*Silicone seals swell in the presence of diesel fuel. This condition may cause excessive connector mate/unmate forces.

REVISION:	ECR/ECN INFORMATION:	TITLE:	SHEET No.
F2	EC No: UAU2016-1352 DATE: 3/09/2016	MX150 16 WAY HYBRID CONNECTOR SYSTEM	11 of 12
DOCUMENT NUMBER:		CREATED / REVISED BY:	CHECKED BY:
PS-33476-000		A. PROFFITT	A. DING
		APPROVED BY:	
		V. KOSHY	



PRODUCT SPECIFICATION

6.4. THIS PRODUCT CONFORMS TO DIN 40 050 1993 WITH THE FOLLOWING CONDITIONS.

- Meets IP6K7

7.0 PACKAGING

- Molex packaging drawing numbers are located on the Assembly Drawing listed in section [2.5](#).
- Parts should be packaged to protect against damage during handling, transit, and storage.

8.0 GAGES AND FIXTURES

All applicable gages and fixtures are referenced in the appropriate control plans.

9.0 OTHER INFORMATION

To add new knock out patterns contact your sales engineer.

MOLEX REPRESENTS AND WARRANTS TO BUYER FOR A PERIOD OF ONE (1) YEAR FROM THE DATE OF DELIVERY OF THE PRODUCTS TO BUYER THAT

- 1) THE PRODUCTS SHALL CONFORM TO THE MOLEX SPECIFICATIONS FOR THE PRODUCTS IN FORCE AT THE DATE OF DELIVERY OF THE PRODUCTS TO BUYER, AND
- 2) THE PRODUCTS SHALL BE OF FREE FROM MATERIAL DEFECTS IN MATERIALS AND MANUFACTURING.

EXCEPT AS EXPRESSLY PROVIDED ABOVE, MOLEX MAKES NO WARRANTY, EXPRESS OR IMPLIED, REGARDING THE PRODUCTS. ALL IMPLIED WARRANTIES, INCLUDING, BUT NOT LIMITED TO, THE IMPLIED WARRANTIES OF FITNESS FOR A PARTICULAR PURPOSE, ARE HEREBY DISCLAIMED. IN ADDITION, MOLEX EXPRESSLY DISCLAIMS ANY WARRANTY OBLIGATIONS IN THOSE INSTANCES WHERE THE FAILURES RESULTED FROM THE MODIFICATION OF THE PRODUCTS BY BUYER OR ITS CUSTOMERS, IMPROPER HANDLING, USE OR INSTALLATION OF THE PRODUCTS BY BUYER OR ITS CUSTOMERS, OR ANY OTHER CAUSE BEYOND THE CONTROL OF MOLEX.

REVISION: F2	ECR/ECN INFORMATION: EC No: UAU2016-1352 DATE: 3/09/2016	TITLE: MX150 16 WAY HYBRID CONNECTOR SYSTEM	SHEET No. 12 of 12
DOCUMENT NUMBER: PS-33476-000	CREATED / REVISED BY: A. PROFFITT	CHECKED BY: A. DING	APPROVED BY: V. KOSHY