

PART NUMBER	REV	FIRST USED
567301-1	E	122500-1
567301-2	E	565435-5

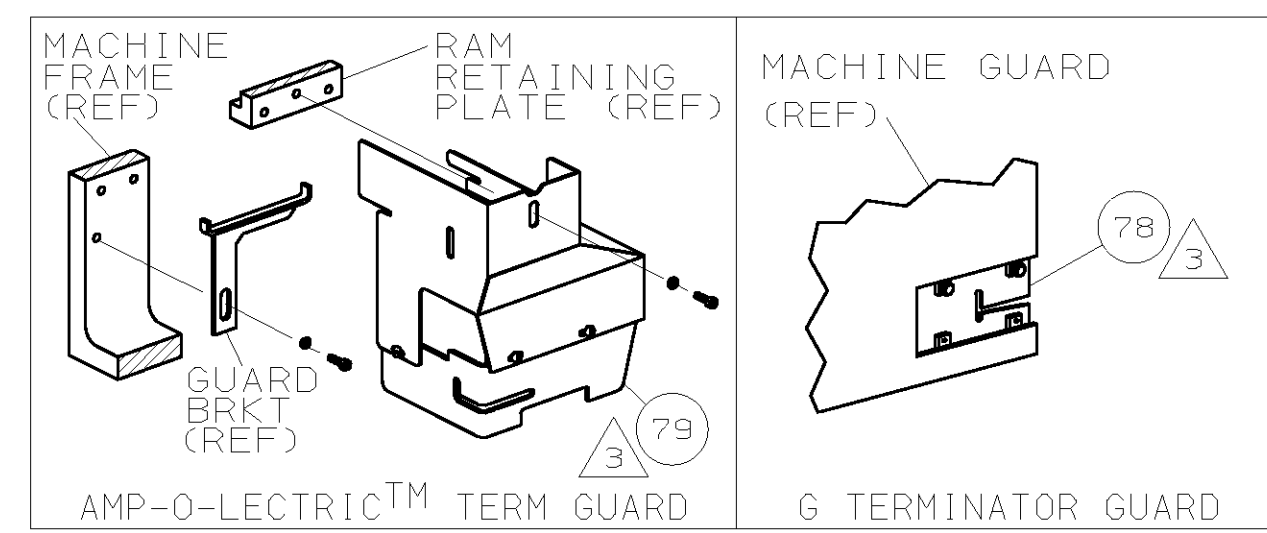

TERMINAL NAME: CLUSTER PIN RECEPTACLE						
770430						
CRIMPING DATA						
PAD LTR	CRIMP HEIGHT		WIRE SIZE			
A	.054 ±.002 [1.37 ±0.05mm]		18			
B	.050 ±.002 [1.27 ±0.05mm]		20			
C	.046 ±.002 [1.17 ±0.05mm]		22			
D	NOT		USED			
CRIMP	SIZE	TYPE	RANGE			
WIRE	.090 [2.29mm]	F	22-18			
INSUL	-	-	-			
WIRE STRIP LENGTH	TERM APPL SPEC	FEED	APPL INSTRUCTION	SET UP GAGE	LAYOUT	
-	114-1025	.630		458638-1	L500	

-1	LEADMAKER & BENCH MODEL G	AIRFEED				
-2	BENCH MODEL K	AIRFEED				
1	-	-	C	692655-5	AIR FEED VALVE ASSY	70
						69
						68
	REF	-	A	24042-2	VALVE, SHUT OFF	67
	REF	-	C	692655-6	AIR FEED VALVE ASSY	66
1	1	-	B	460277-1	AIR FEED ASSY (1 INCH)	65
2	2	-	A	3-21000-9	SCR, 5HC (10-32x1.00) AIR ASSY	64
-	1	-	A	983427-6	ELBOW, SWIVEL 1/8 NPT - 1/4 T	63
-	1	-	A	23238-1	QUICK DISCONNECT	62
-	12.00	IN	A	27319-4	TUBING, POLY-FLO Ø.25	61
						60
1	1	-	C	454220-1	CAP, RAM	59
1	1	-	D	453736-1	HOUSING	58
						57
						56
						55
						54
1	1	-	B	460680-2	FEED FINGER ASSY	53
						52
						51
						50
						49
-	1	-	A	22374-7	VALVE, QUICK EXHAUST	48
-	1	-	A	22304-1	NIPPLE, HEX 1/8 NPT	47
						46
1	1	-	A	690191-1	PLUG, NYLON	45
1	1	-	C	455674-1	RAM	44
1	1	-	A	690125-1	WASHER, LAMINATED	43
1	1	-	A	690124-1	WASHER, RAM	42
1	1	-	A	7-21002-9	BOLT, CRIMPER (5/16-24x1.00)	41
						40
						39
1	1	-	A	690223-2	SPACER, INSULATION DISC	38
1	1	-	D	354777-1	WIRE DISC, PLASTIC	37
1	1	-	A	22480-5	WASHER, SPRING	36
1	1	-	B	690212-1	POST, RAM	35
						34
						33
						32
						31
						30
						29
						28
1	1	-	A	462505-1	STRIPPER	27
1	1	-	D	455676-1	PLATE, BASE	26
2	2	-	A	22354-8	DRAG, STUD	25
1	1	-	B	455678-1	PLATE, STRIP GUIDE	24
1	1	-	C	240825-2	PLATE, STRIP HOLD DOWN	23
2	2	-	A	4-22281-1	SPRING, DRAG	22
						21
1	1	-	A	454177-1	DRAG, STOCK	20
						19
2	2	-	C	454204-5	GUIDE, STRIP (FRONT)	18
						17
						16
						15
						14
1	1	-	C	690481-7	SPACER, HOLD DOWN	13
1	1	-	A	23846-1	SPRING, HOLD DOWN	12
1	1	-	B	240644-1	PLATE, REAR SHEAR	11
2	2	-	C	1-240645-5	SPACER, SHEAR PLATE	10
1	1	-	B	240642-4	PLATE, FRONT SHEAR	9
1	1	-	D	1-240654-2	ANVIL	8
1	1	-	B	5-240651-3	BLADE, SLUG	7
1	1	-	D	455892-5	HOLD DOWN, TERMINAL	6
1	1	-	C	3-240641-0	SPACER, SLUG BLADE	5
						4
						3
						2
1	1	-	C	3-456406-3	CRIMPER, WIRE	1

THIS DRAWING IS A CONTROLLED DOCUMENT.

THIS DRAWING IS UNCLASSIFIED... RELEASED FOR PUBLICATION... BY AMP INCORPORATED. ALL RIGHTS RESERVED. OCT 1999

LOC A DIST 66

- ① RECOMMENDED SPARE PARTS.
- ② GREASE LIGHTLY.
- ③ GUARD MUST BE IN PLACE WHEN OPERATING APPLICATOR IN A BENCH MACHINE.
- ④ SEE DRAWING FOR COMPONENTS
- ⑤ ITEM 78 IS USED ON BENCH MODEL G ONLY.

QTY	RECD PER ASSY	U/M	DWG SIZE	PART NO	DESCRIPTION	ITEM NO
2	2	-	C	3-354779-0	PIN, WIRE DISC (.3140)C	129
2	2	-	C	2-354779-2	PIN, WIRE DISC (.3100)B	128
2	2	-	C	1-354779-4	PIN, WIRE DISC (.3060)A	127
1	1	-	A	986950-1	WASHER, FLAT PRECISION	125
						124
						123
						122
						121
						120
						119
						118
						117
						116
						115
						114
2	2	-	A	21024-5	WASHER, LOCK (#10) AIR ASSY	113
						112
						111
7	7	-	A	21024-4	WASHER, LOCK (NO.8) SHEAR BL	110
						109
2	2	-	A	21018-4	NUT, HEX (4-40) DRAG	108
						107
						106
2	2	-	A	21022-2	NUT, HEX SL (8-32) DRAG STUD	105
						104
						103
2	2	-	A	2-21006-6	SCR, SKT SET (4-40x.62) DRAG	102
1	1	-	A	21009-2	SCR, SKT SET (1/4-20x.25) RAM	101
2	2	-	A	21017-2	SCR, DRIVE (#2x.19) ID PLATE	100
						99
1	1	-	B	461264-1	PLATE, IDENTIFICATION	98
						97
						96
2	2	-	A	2-21002-2	SCR, BHC (8-32x.50) STRIPPER	95
4	4	-	A	2-21002-9	SCR, BHC (10-32x.75) CAP	94
1	1	-	A	22733-8	SCR, BHC (8-32x.38 LW) ANVIL	93
4	4	-	A	3-21002-3	SCR, BHC (1/4-20x.50) ST 6D PL	92
3	3	-	A	2-22733-8	SCR, BHC (1/4-20x.62) H5G	91
						90
						89
						88
2	2	-	A	2-21000-7	SCR, 5HC (8-32x.50) SLUG BLADE	87
3	3	-	A	2-21000-6	SCR, 5HC (8-32x.38) STRIP GUIDE	86
2	2	-	A	2-21000-9	SCR, 5HC (8-32x.75) R STRIP GUIDE	85
						84
						83
						82
						81
2	2	-	A	3-21002-0	SCR, BHC (10-32x.88) SHEAR PL	80
1	-	-	A	455750-8	GUARD ASSY	79
-	REF	-	A	679532-1	INSERT, GUARD	78
						77
						76
						75
						74
						73
						72
						71

QTY	RECD PER ASSY	U/M	DWG SIZE	PART NO	DESCRIPTION	ITEM NO
-2	-1					

QTY RECD PER ASSY		PARTS LIST	

QTY	RECD PER ASSY	U/M	DWG SIZE	PART NO	DESCRIPTION	ITEM NO
-2	-1					

DIMENSIONS IN INCHES. DO NOT SCALE PRINT. TOLERANCES UNLESS OTHERWISE SPECIFIED:

2 PLC DEC ±.25  
3 PLC DEC ±.  
4 PLC DEC ±.

ANGLES ± - SURF TEXTURE. ✓ REMOVE BURRS, BREAK SHARP EDGES R.015 MAX

MATL - HT TR - FIN -

DR D. SALTZER 10-30-95 APP T. BEDDICK 11-8-95  
CHK 11-8-95 REL 11/21/95  
C. ERISMAN B. MORGAN

**AMP** AMP Incorporated Harrisburg, PA 17105-3608

NAME END FEED HDM APPLICATOR MACHINE REF  
SCALE 1 OF 1 REV E1  
DWG NO 567301

CASE CODE 00779 CUSTOMER AND ASSEMBLY DRAWING 1 RESTRICTED TO