

REVISIONS							
LOC	QIST	P	F	ZONE	LTR	DESCRIPTION	
CM	53				C	REV & REDWN PER CM-11	
						DATE	APPD
						11-4-93	KW

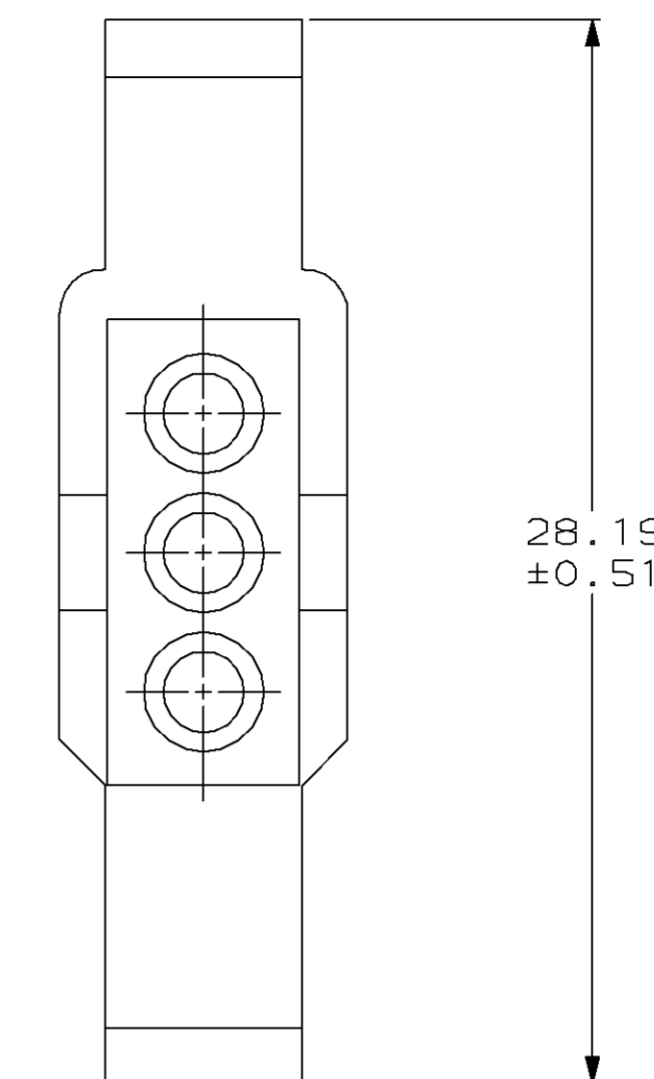

△ AMP LOGO AND CAVITY NUMBER LOCATED ON EITHER SURFACE.

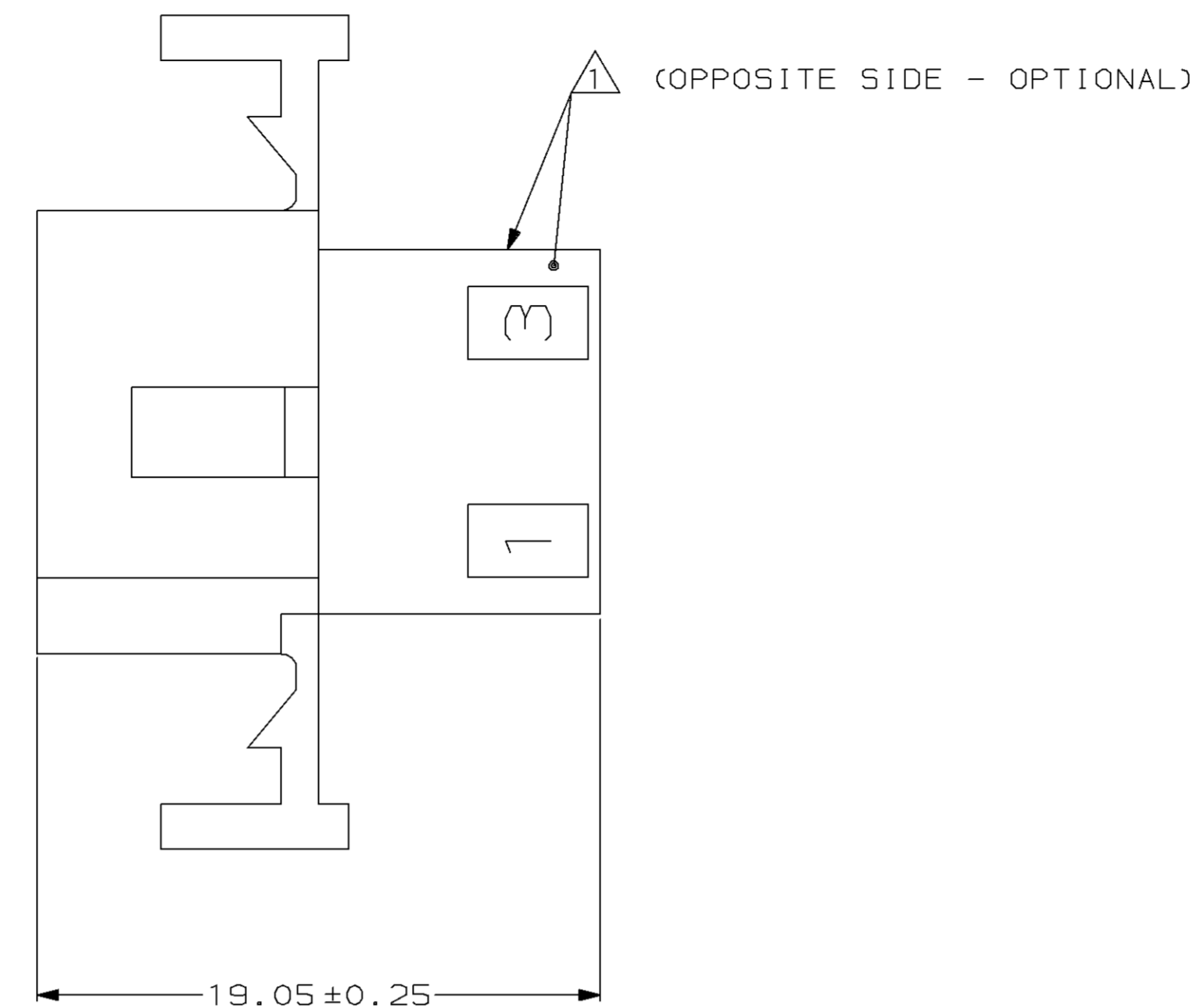
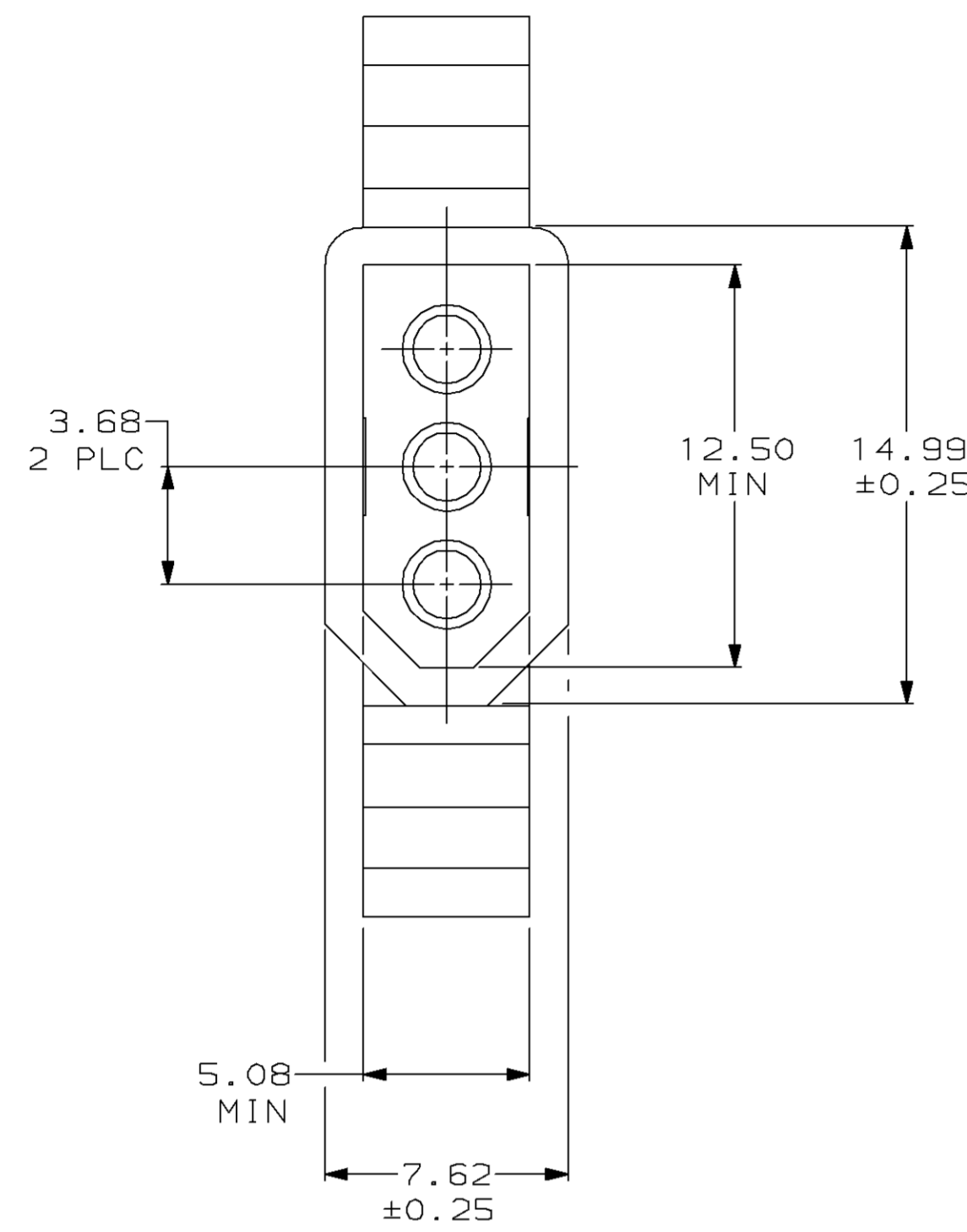
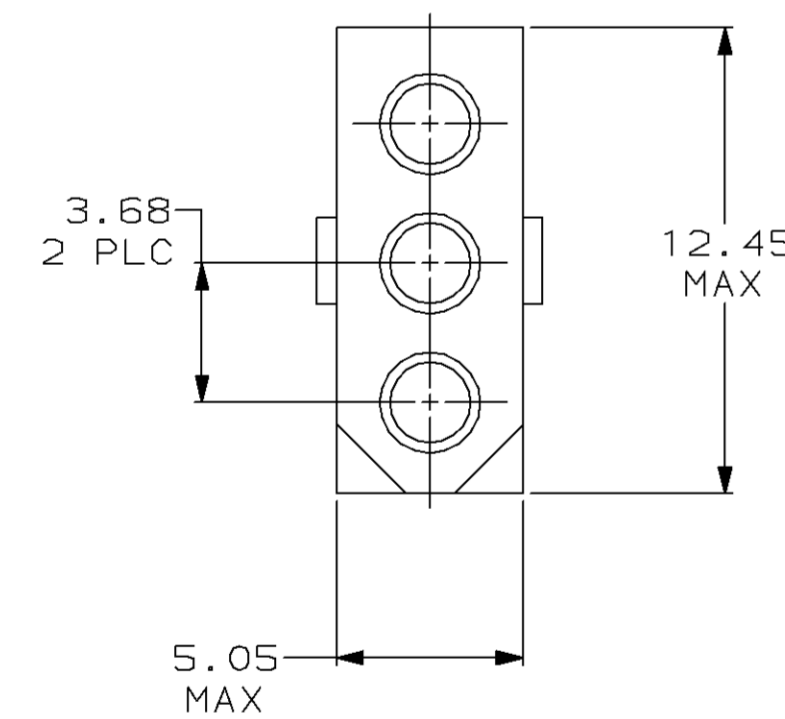

MATING CONNECTOR INTERFACE

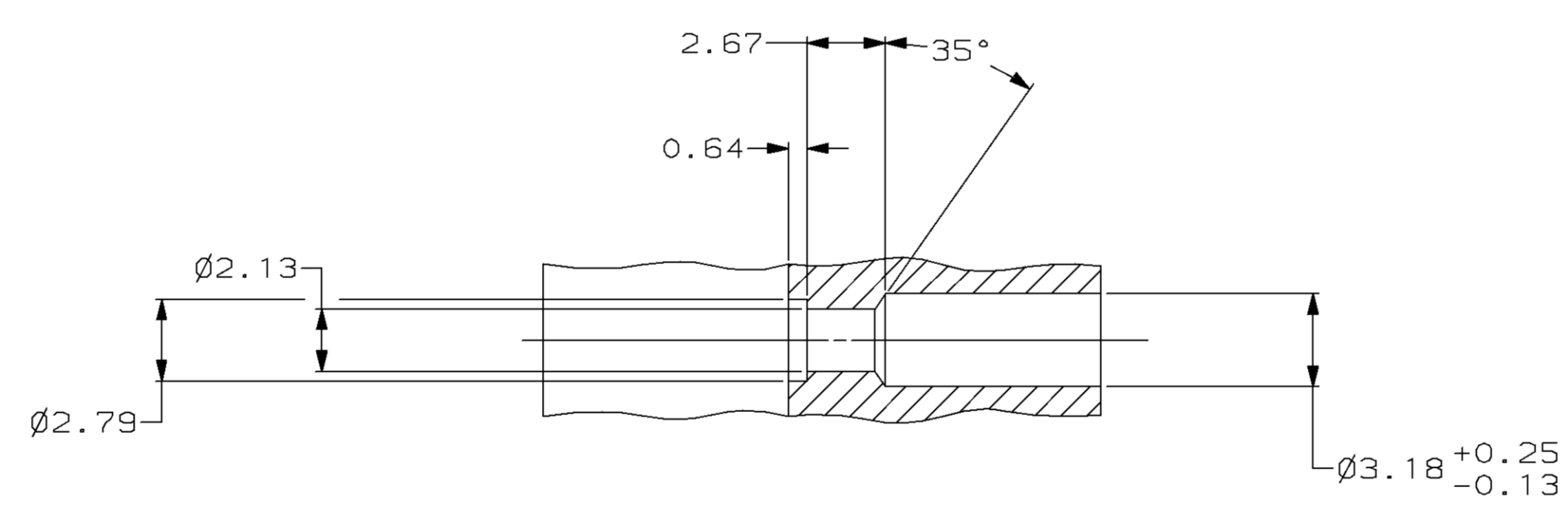

TYPICAL PLUG CAVITY SECTION (DIMENSIONS REFERENCE ONLY)

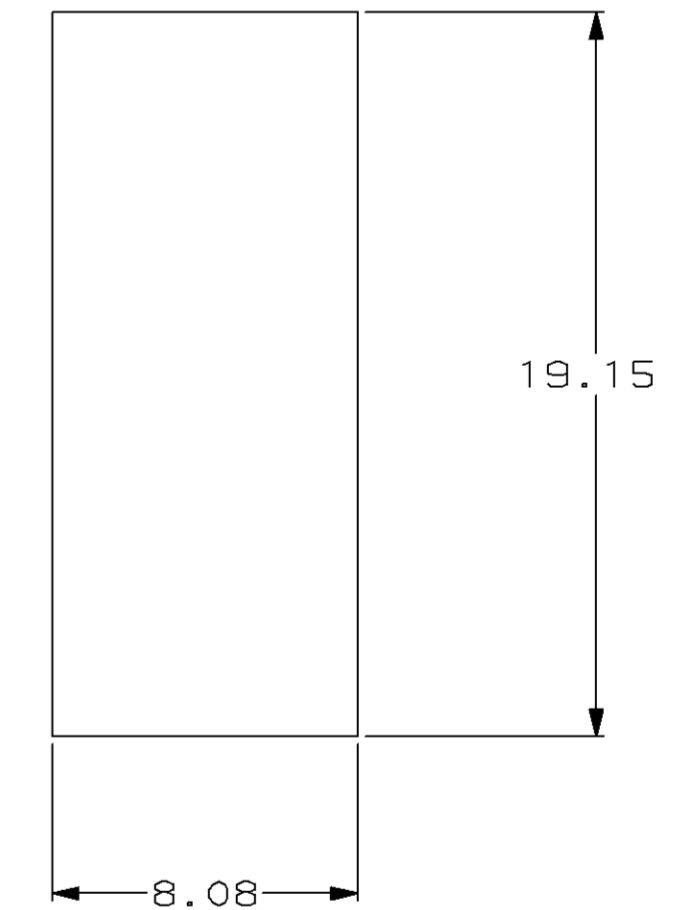

RECOMMENDED CUT OUT FOR 1.52 MAX THICK PANEL

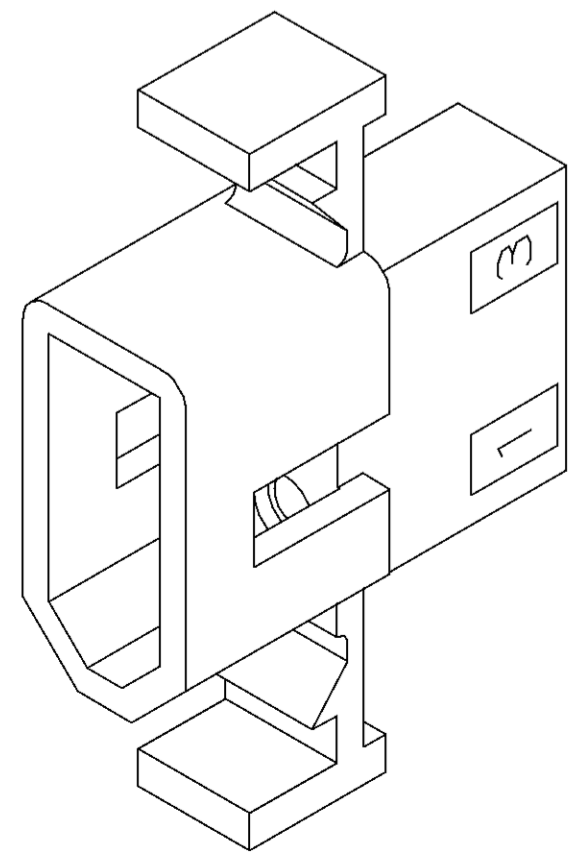

3-DIMENSIONAL MODEL NTS

MM	IN	MM	IN	MM	IN
2.13	.084	7.62	.300	28.19	1.110
1.57	.062	5.08	.200	19.15	.754
1.52	.060	5.05	.199	19.05	.750
0.64	.025	3.68	.145	14.99	.590
0.51	.020	3.18	.125	12.50	.492
0.25	.010	2.79	.110	12.45	.490
0.13	.005	2.67	.105	8.08	.318

CONVERSION TABLE

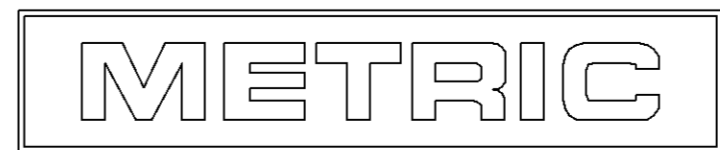

THIS DRAWING IS A CONTROLLED DOCUMENT FOR AMP INCORPORATED. IT IS SUBJECT TO CHANGE AND THE CONTROLLING ENGINEERING ORGANIZATION SHOULD BE CONTACTED FOR THE LATEST REVISION.

DO NOT SCALE PRINT. UNLESS SPECIFIED DIMENSIONS IN mm [INCHES]		DR 11-4-93 K. WHITAKER	770332-1 PART NO	
TOLERANCES ON: 2 PLC DEC ± 0.13 3 PLC DEC ± - ANGLES ± 1°0'		CHK 11-4-93 R. SWING	AMP Incorporated Harrisburg, PA 17105-3608	
MATERIAL NYLON, UL 94V-2 NATURAL		APPD 11-4-93 C. CASH	NAME PLUG, PANEL MOUNT, 3 CIRCUIT, .062 PIN AND SOCKET	
FINISH -		APPD 11-4-93 C. CASH	PRODUCT SPEC -	
APPLICATION SPEC -		APPD 11-4-93 C. CASH	SIZE D	CAGE CODE 00779
WEIGHT -			DRAWING NO C-770332	
			SCALE 5:1	SHEET 1 OF 1