

The RF2411 General Purpose UHF Downconverter IC

Introduction

Communication receivers are constructed using a superheterodyne architecture. The received signal frequency is converted to a lower "intermediate" frequency (IF) in one or more steps for efficient amplification, filtering, and detection. The first down-converter circuit is often the primary determinant of overall receiver performance. This circuit typically consists of a band-limiting preselector filter (which may actually be the receive path of a duplexer), a low-noise amplifier (LNA), an image filter, a mixer, and a local oscillator.

The RF2411 is a monolithic integrated circuit UHF receiver downconverter which implements all of the RF functions of the required circuitry except passive filters and local oscillator in a 14-lead small outline plastic package. The block diagram of the device is included in Figure 1. It is suitable for general application in the

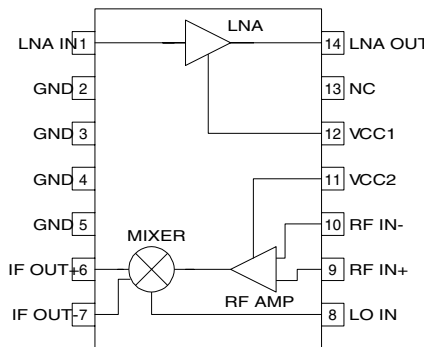

Figure 1: RF2411 Functional Block Diagram

500MHz to 1900MHz frequency range, at power supply voltages from 3V to 6V. Its high level of performance with a minimum of external components is a direct result of the advanced heterojunction bipolar transistor (HBT) IC process used. Broadband impedance matching at the RF ports and flexible IF interface simplify application to many receiver systems.

LNA Description

The LNA achieves broadband impedance match to 50Ω and low noise figure through internal feedback circuitry, not by use of external components. Input return loss is greater than 20dB and output return loss is greater than 10dB over the entire 1MHz to 1500MHz range. LNA gain slopes from 17dB at 1MHz to 11dB at

1500MHz, as plotted in Figure 2. LNA reverse isolation

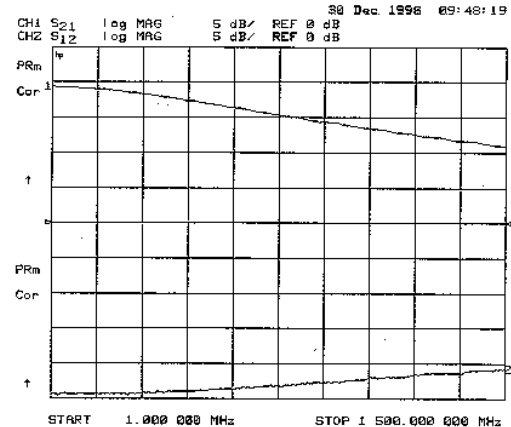

Figure 2: LNA Gain and Reverse Isolation vs. Frequency

is high over the full frequency range, decreasing from 24dB at 1MHz to 21dB at 1500MHz. Noise figure is low and almost flat, increasing from 1.7dB at 500MHz to 2.4dB at 1500MHz, as plotted in Figure 3.

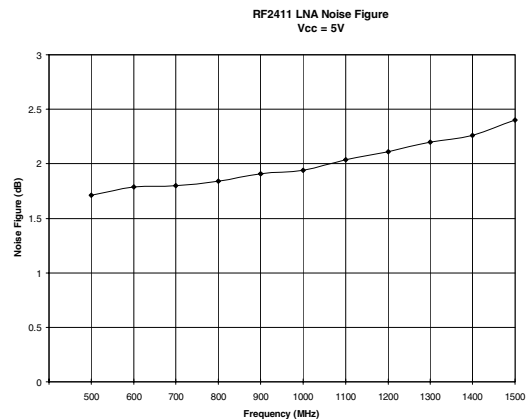

Figure 3: Noise Figure vs. Frequency

There is a dependence of LNA noise figure, gain, and IIP3 on power supply voltage at 880MHz. Gain can be seen to decrease from 14.6dB to 11.8dB as V_{CC} is reduced from 5V to 2.5V. IIP3 decreases from -1.75dBm to -11.6dBm, and noise figure decreases slightly from 1.88dB to 1.7dB over the same supply voltage range.

The excellent broadband impedance match insures optimum duplexer and image filter performance. In addition, the wideband gain, noise and isolation characteristics guarantee simple application to many UHF receiver systems.

Mixer Description

The RF2411 mixer is a double-balanced “Gilbert” type with differential IF output taken as open collectors for flexible IF interface. The RF input is typically matched to 50Ω system impedance using a single external series inductor, in this case 27nH, to cancel capacitive reactance. The LO input is internally matched over the full frequency range. LO input return loss increases from 11dB at 1MHz to 22dB at 1500MHz.

The doubly-balanced mixer delivers greater than 30dB LO input to mixer RF input isolation. LO input to IF output isolation is typically greater than 30dB over the 1MHz to 1500MHz range for differential IF interface. Mixer RF to IF isolation is typically greater than 25dB over the 400MHz to 1500MHz range.

Mixer conversion gain is dependent upon details of the IF interface. Power gain is directly dependent upon interface impedance. A 1000Ω interface impedance will result in 3dB more conversion gain than a 500Ω interface impedance, for example. Also, a differential interface will result in 6dB more gain than a single-ended interface at the same impedance level.

A differential interface can be through a balun transformer or directly to a differential SAW IF filter. Alternately, one collector may be tied directly to V_{CC} and output taken single-ended from the remaining output. In either case, maximum performance in typical application is obtained connecting the mixer collector(s) to V_{CC} through inductors resonant with the IF circuit capacitance, including circuit board trace and filter capacitance, so that the interface is entirely resistive at the IF frequency. The output capacitance of the mixer itself is less than 1 pF per collector.

Figure 4 shows the dependence of mixer noise figure, gain, and IIP3 on power supply voltage at 880MHz RF and 965MHz LO (85MHz 1000Ω differential IF inter-

face). Gain can be seen to decrease from 12.8dB to

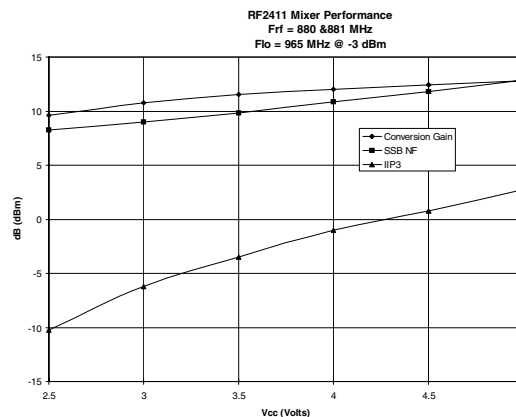

Figure 4: Mixer Gain, Noise Figure, and IIP3 vs. Supply Voltage

9.6dB as V_{CC} is reduced from 5V to 2.5V. IIP3 decreases from +2.8dBm to -10.3dBm, and SSB noise figure decreases from 12.85dB to 8.22dB over the same voltage range. This characteristic indicates best noise figure but poorer IIP3 and gain (and thus higher noise contribution from following components) at lower power supply voltage compared with $V_{CC}=5V$.

Figure 5 shows the dependence of mixer gain, noise figure, and IIP3 on LO input power ($V_{CC}=5.0V$, $F_{RF}=880MHz$ and $881MHz$, $F_{LO}=965MHz$, $F_{IF}=85MHz$, 1000Ω differential interface). Conversion

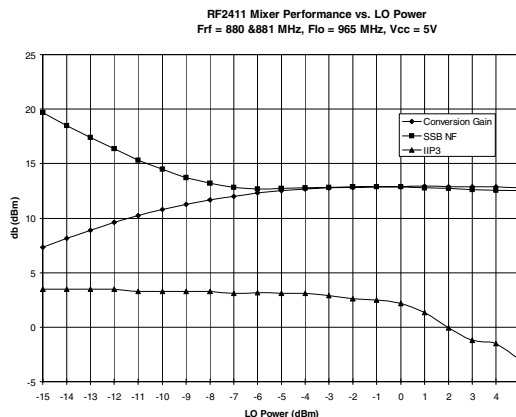

Figure 5: Mixer Gain, Noise Figure, and IIP3 vs. LO Power

gain and noise figure are only weakly dependent upon LO drive between -6dBm and +5dBm. IIP3 is maximum (+3.5dBm) at lowest LO drive, decreasing to 2.9dBm at -3dBm and more sharply to -3dBm at +5dBm LO drive. This characteristic indicates optimum

mixer performance at LO drive levels between -7dBm and -4dBm.

Application Example

A typical application is diagrammed in Figure 6. Similar

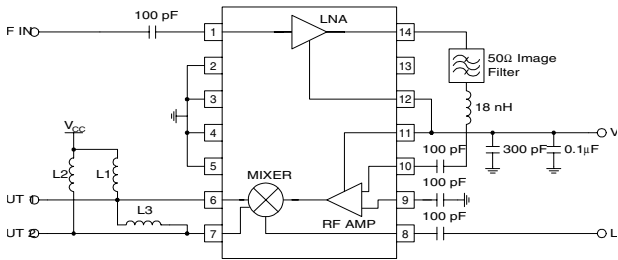

Figure 6: Schematic for Typical Application

to many cellular phone receiver applications, a monolithic image filter and interface to a differential IF filter are utilized. The IC RF ports are not blocked to DC by internal capacitors since the typical monolithic duplexer and image filters do not present a DC path. The only external components necessary in such an application are the series inductor at the mixer RF port, a broadband AC bypass at the IC V_{CC} pins, and the IF interface components. The IF interface components can be simply two chip inductors to power supply as shown, connecting to a differential input SAW IF filter such as the Sawtek 854596. The inductor value is chosen to resonate with filter and circuit board stray capacitance at the IF frequency. The mixer interface impedance is set by the filter input impedance in this example circuit, 1000 Ω (differential) for the Sawtek filter. Alternately, impedance transformation may be included in the interface circuit to a higher impedance to increase conversion gain or to a lower impedance to increase mixer 1dB compression point. In all cases ground connections must be low inductance paths directly to a good RF ground plane.

Figure 7 shows the dependence of overall cascaded noise figure, gain, IIP3, and DC current drain on power supply voltage for such a configuration at 880MHz RF and 965MHz LO (85MHz 1000 Ω differential IF inter-

face). The image filter loss is 3dB at 880MHz. Gain

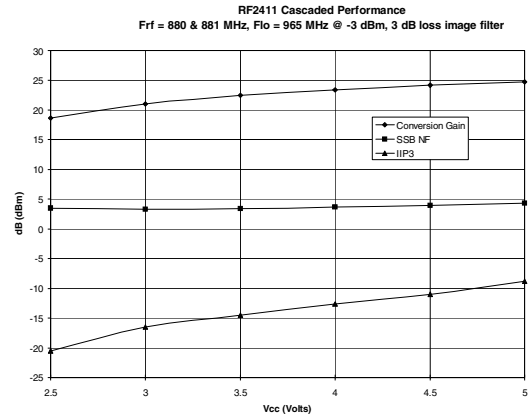

Figure 7: Cascaded Noise Figure, Gain, and IIP3, and Current Drain vs. Supply Voltage

can be seen to decrease from 24.8dB to 18.7dB as V_{CC} is reduced from 5V to 2.5V. IIP3 decreases from -8.8dBm to -20.5dBm largely due to the mixer. Noise figure decreases from 4.4dB at 5V to a minimum of 3.3dB at 3V.

LO leakage to the LNA input is less than -43dBm with 0dBm LO input power. This value is less than the sum of LNA and mixer reverse isolation, indicating degradation by a leakage mechanism external to the IC.

Conclusion

The RF2411 integrates the LNA and mixer of a high-performance UHF receiver downconverter in a 14 lead small outline plastic package. Its broadband characteristics extend the useful frequency range from 500MHz to 1900MHz frequency range. The flexible IF interface accommodates single-ended and differential filters from < 400kHz to > 200MHz. It is especially useful in portable equipment, requiring the bare minimum of external components to minimize total circuit size and cost.

