

EVALUATION BOARD MANUAL
EBSGJN Series
EBAGJN Series

EVALUATION KIT MANUAL
EKSGJN Series
EKAGJN Series

for EYSGJN, EYAGJN series Bluetooth® Smart Module

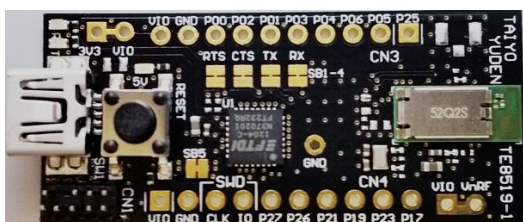

Introduction

This evaluation board is applicable for Taiyo Yuden's **Bluetooth® 4.2 Low Energy** module, EYSGJN and EYAGJN Series.

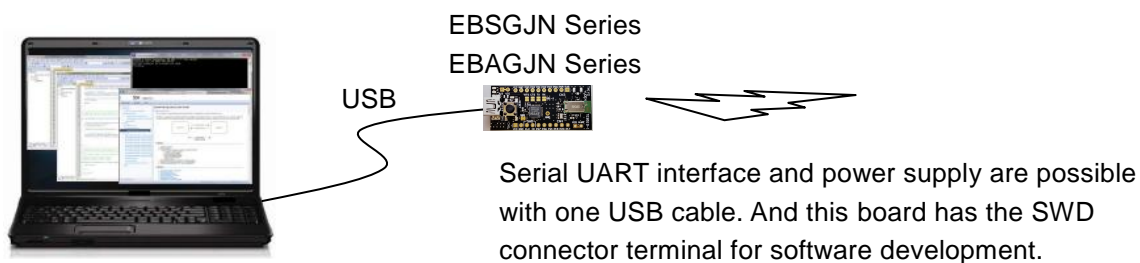

Mounted module

EYSGJN or EYAGJN (11.3mm x 5.1mm x 1.3mm_MAX)

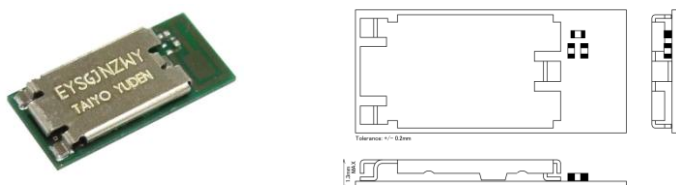

Nordic nRF51822 / ARM® Cortex™-M0 32 bit processor
28-pin Land Grid Array / 14GPIOs / SWD

- Basic Module -

Taiyo Yuden writes firmware for S120 (EYSGJNZWY) or S310 (EYAGJNZXX) SoftDevice to this product.
The user can develop unique application for the module.

Content

1	EBSGJN Series or EBAGJN Series Evaluation Board (PCB name_TE8519-1)	1 pc
2	CD-ROM (DataReport, EVBManual)	1 set
3	J-Link Lite (EKSGJNZWY or EKAGJNZXX Only)	1 set



Evaluation board circuit schematic

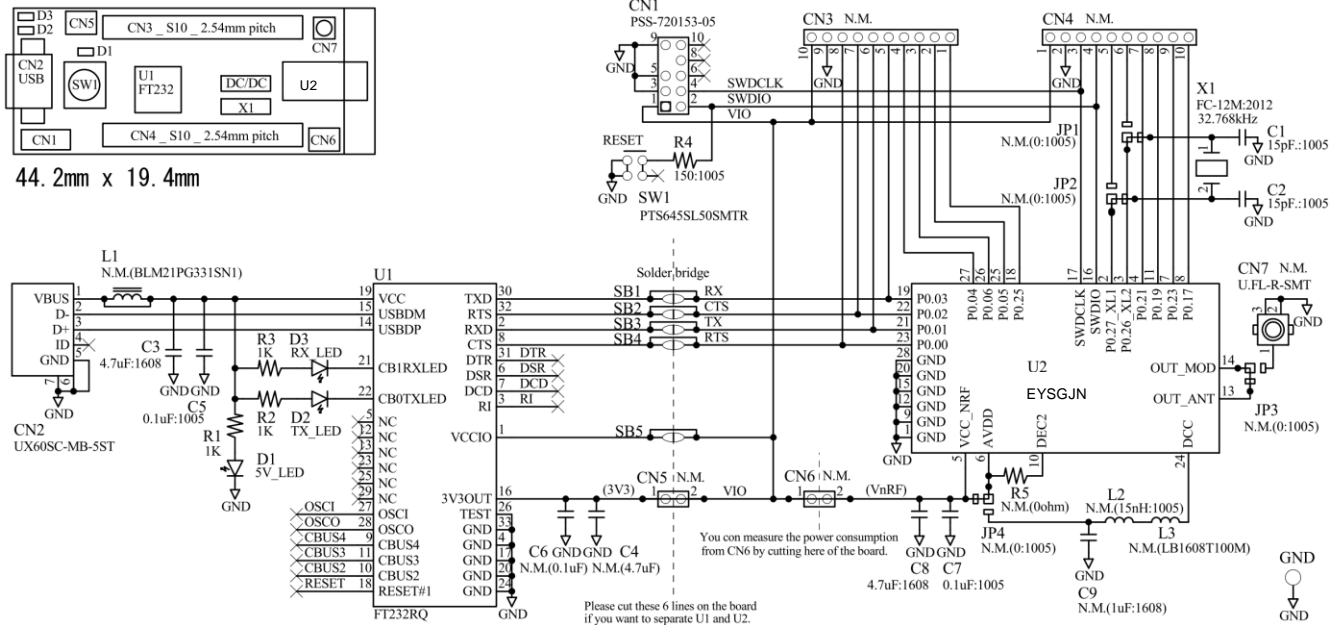

Evaluation board layout

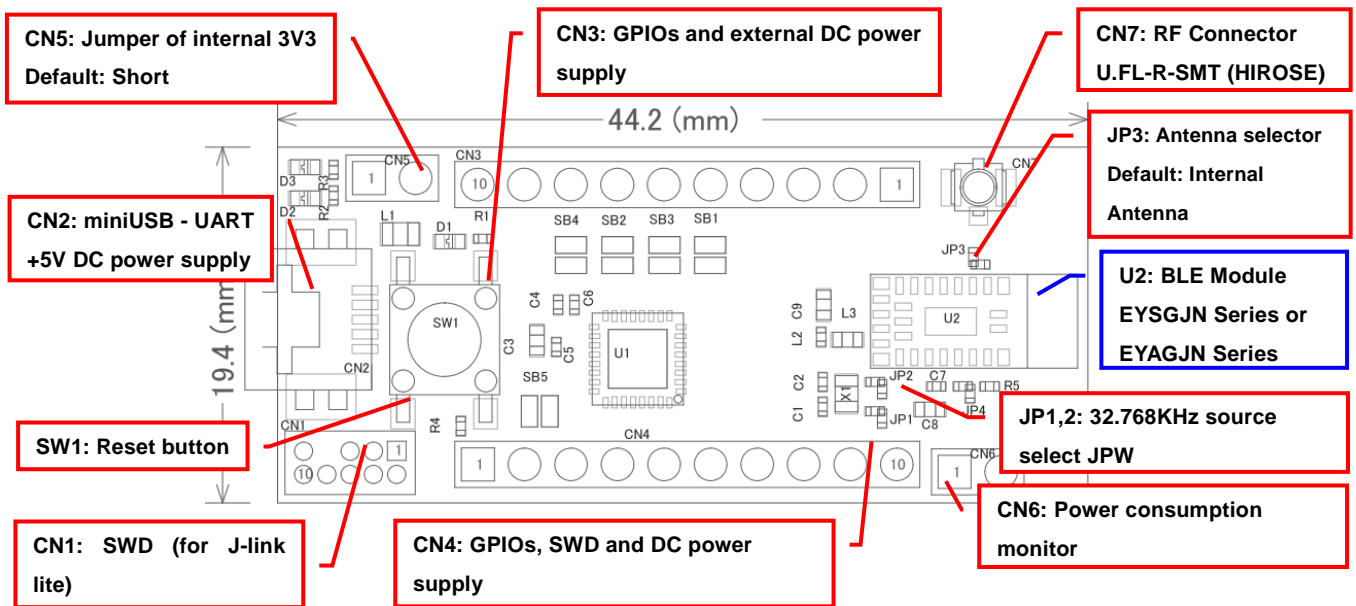

- 1) All pin headers are 2.54mm pitch. And distance between **CN3** and **CN4** is **15.24mm**.
- 2) **CN3-CN6, C1-C2, C4, C6, C9, L1-L3, JP1-JP4, SB1-5, R5** are not mounted (N.M.).
- 3) **D1 (LED)**: USB VBUS 5V LED Indicator
- 4) **D2 (LED)**: UART TX Indicator
- 5) **D3 (LED)**: UART RX Indicator
- 6) **SW1 (Push button)**: Module Reset (active low)

Silkscreen Printing

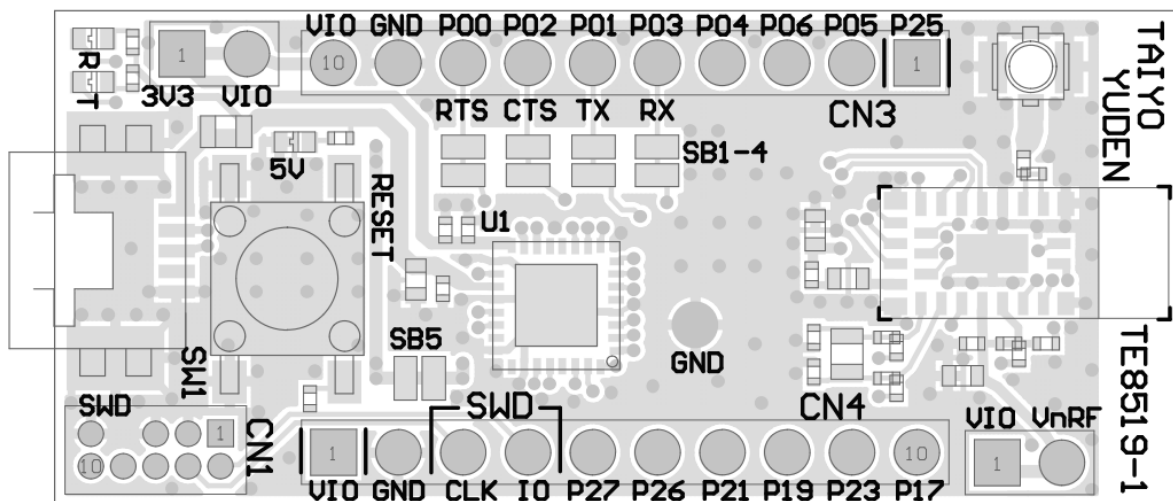

Pin Descriptions

Pin No.	CN3	CN4
1	P0.25	VIO
2	P0.05	GND
3	P0.06	SWDCLK
4	P0.04	SWDIO
5	P0.03	P0.27
6	P0.01	P0.26
7	P0.02	P0.21
8	P0.00	P0.19
9	GND	P0.23
10	VIO	P0.17

How to use

It is very easy just to tie this board to the PC with a USB cable. It is not necessary to change the setting of the board. The power supply of the module supplies by default 3.3V from 3V3OUT of FT232RQ.

For software development

Nordic-DK and Use case

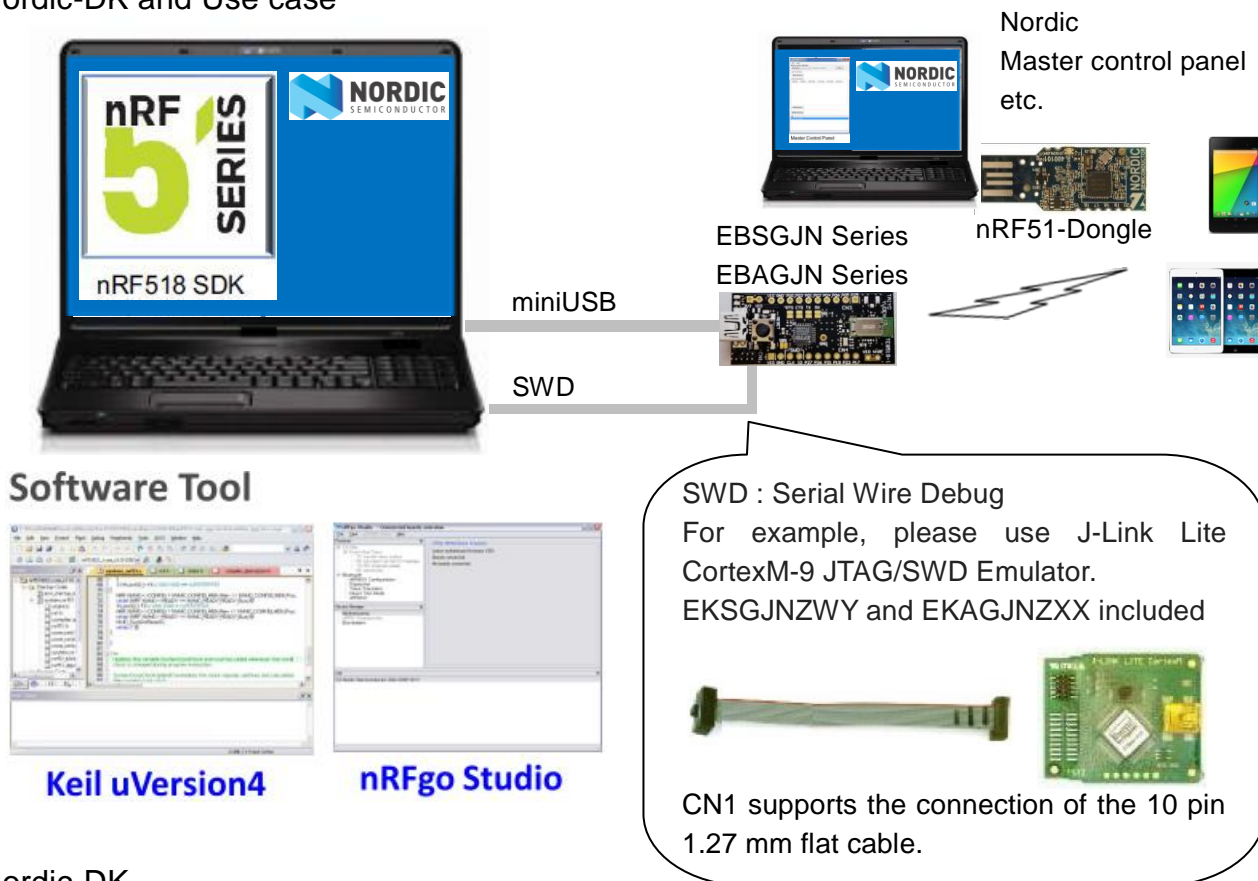

Nordic-DK

<http://www.nordicsemi.com/eng/Products/nRF51-DK>

Nordic-nRF51DK

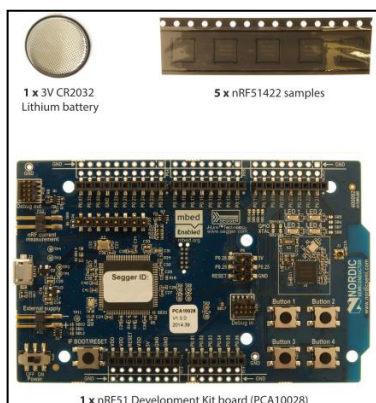

MEMO

1) Current measurement

To measure the current, please cut the shorting 1pin and 2 pin of CN6. And connect an ampere-meter between the pins of connector CN6 to monitor the current directly.

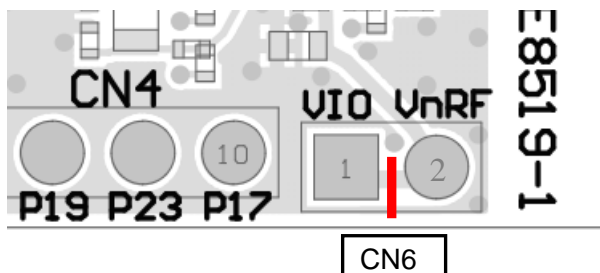

2) About the power supply of the module

When you use external power supply, please supply power from 9pin and 10pin of CN3. On this configuration, you cut short circuit 1pin and 2pin of CN5 and should separate 3V3OUT of FT232RQ.

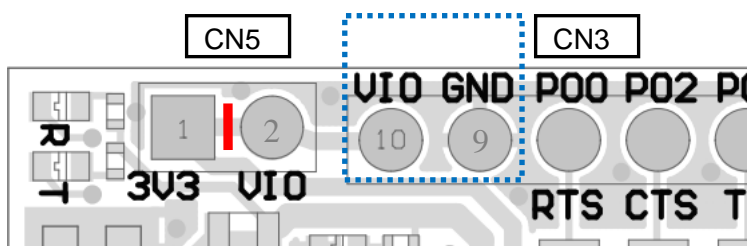

3) USB to serial UART interface

It needs to install driver of FT232RQ to use USB for UART interface. The drivers are available on FTDI website.

<http://www.ftdichip.com/Drivers/D2XX.htm>

In addition, by the application development, please assign GPIO as follows.

GPIO	UART
P0.00	RTS
P0.01	TX
P0.02	CTS
P0.03	RX

Important notes

The evaluation board included with the Nordic Development Kit uses a 16MHz clock. Therefore the sample code from Nordic is designed to be used with a 16MHz clock. On the other hand, the EYSGJN and EYAGJN series module uses a 32MHz system clock, making it incompatible with the Nordic sample code (i.e. sample code does not configure HFCLK: XTALFREQ register for **32MHz**). To fix this issue, we need to write the value 0xFFFFFFFF to the UICR (User Information Configuration Register) at address 0x10001008. Please note that the UICR is erased whenever you download a SoftDevice.

The UICR can be written by using the debug tools:

```
nrfjprog.exe --snr <your_jlink_debugger_serial_number> --memwr 0x10001008 --val 0xFFFFFFFF
```

Or the following code can be added to the SystemInit function in the system_nRF51.c file, right before launching the TASK_HFCLKSTART task:

```
if (*(uint32_t *)0x10001008 == 0xFFFFFFFF)
{
    NRF_NVMC->CONFIG = NVMC_CONFIG_WEN_Wen << NVMC_CONFIG_WEN_Pos;
    while (NRF_NVMC->READY == NVMC_READY_READY_Busy){}
    *(uint32_t *)0x10001008 = 0xFFFFFFFF;
    NRF_NVMC->CONFIG = NVMC_CONFIG_WEN_Ren << NVMC_CONFIG_WEN_Pos;
    while (NRF_NVMC->READY == NVMC_READY_READY_Busy){}
    NVIC_SystemReset();
    while (true){}
}
```



32kHz Clock

This module does not installed 32.768kHz crystal. In case of operating without external crystal, please use following example code in order to enable internal 32.768kHz RC oscillator (32k RCOSC).

```
SOFTDEVICE_HANDLER_INIT(NRF_CLOCK_LFCLKSRC_RC_250_PPM_250MS_CALIBRATION, false);
```

Note that when you choose to use the RC oscillator, it will add around 10uA average current consumption compared to a 20ppm external crystal.

TYSA-B or TYSA-B Lite Installation model

TYSA-B (Taiyo Yuden Standard Application for BLE)
BLE Embedded Software

EYSGJNA Series. (11.3mm x 5.1mm x 1.3mm_MAX)

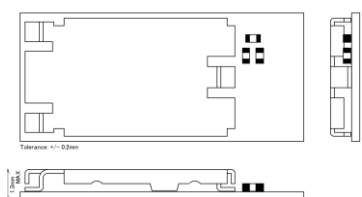

Nordic nRF51822 / ARM® Cortex™-M0 32 bit processor

TYSA-B is installed.
Development of the application software in the module is unnecessary.

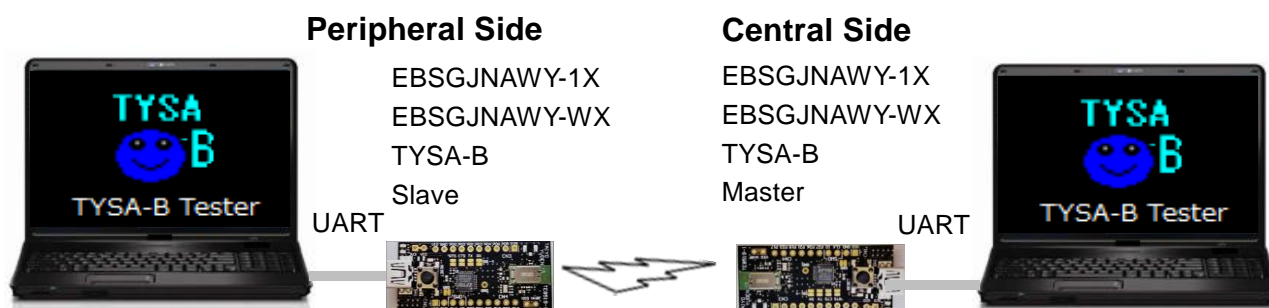

TYSA-B and TYSA-B Lite



TYSA-B

